



EAST CAMBRIDGESHIRE  
DISTRICT COUNCIL  
Local Development Framework

# Shop Front Design Guide

Supplementary  
Planning Document

MAY 2010



# CONTENTS

	<b>Introduction</b>	1
<b>1</b>	<b>Components of a Shop front</b>	2
<b>2</b>	<b>Principles of Shop front Design</b>	4
<b>3</b>	<b>Design Criteria for quality shop front</b>	6
	General principles	6
	Scale, height and proportion	6
	Access for all	7
	Doors and entrances	7
	Fascias and detailing	8
	Stall risers	10
	Windows and Glazing	10
	Materials	11
	Colour	12
<b>4</b>	<b>Other Key Elements of shop front design</b>	13
	Signs and advertising – general principles	13
	Fascia signs	13
	Fascia sign lettering	14
	Hanging signs	15
	Box signs	16
	Nameplates	17
	Lighting	17
	Blinds and canopies	18
	Security	19
	Permissions required for installation of security measures	21
<b>5</b>	<b>Useful contacts</b>	23
<b>6</b>	<b>Relevant planning policies</b>	24

## INTRODUCTION

Within East Cambridgeshire there are many examples of retail centres and villages in which traditional and attractive characteristics survive, many of which also feature historic buildings at their core. The use of statutory designations such as Listed Building and Conservation Areas provide an opportunity to preserve and enhance these centres, making them attractive and lively places for people to live and visit.

Shop fronts are the main advertising method for retailers and are required to be eye-catching as well as conveying the type of business offered. In order to maintain the character of retail areas, a concerted effort from all involved is required. If well designed, shop fronts can make a positive contribution to the character and trading success of an individual street or shopping centre.

The purpose of this guide is to encourage greater care to be taken in shop front design and promote high quality design standards within the Districts retail centres in order to create settings in which retailers can establish and develop successful businesses.

To understand the issues, this guide has been arranged into four main sections:

- 1 The components of a shop front;
- 2 The principles governing shop front design;
- 3 Design criteria for quality shop fronts:
  - Scale, height and proportion
  - Access for all
  - Doors and entrances
  - Fascia and detailing
  - Stall risers
  - Windows and glazing
  - Materials
  - Colour
- 4 Other Key Elements of shop front design:
  - Fascia signs
  - Fascia sign lettering
  - Hanging signs
  - Box signs
  - Nameplates
  - Lighting
  - Blinds and canopies
  - Security

# 1 Components of a shop front

1.1 Shop fronts are composed of a number of functional elements and architectural features that work together to form a visual framework.

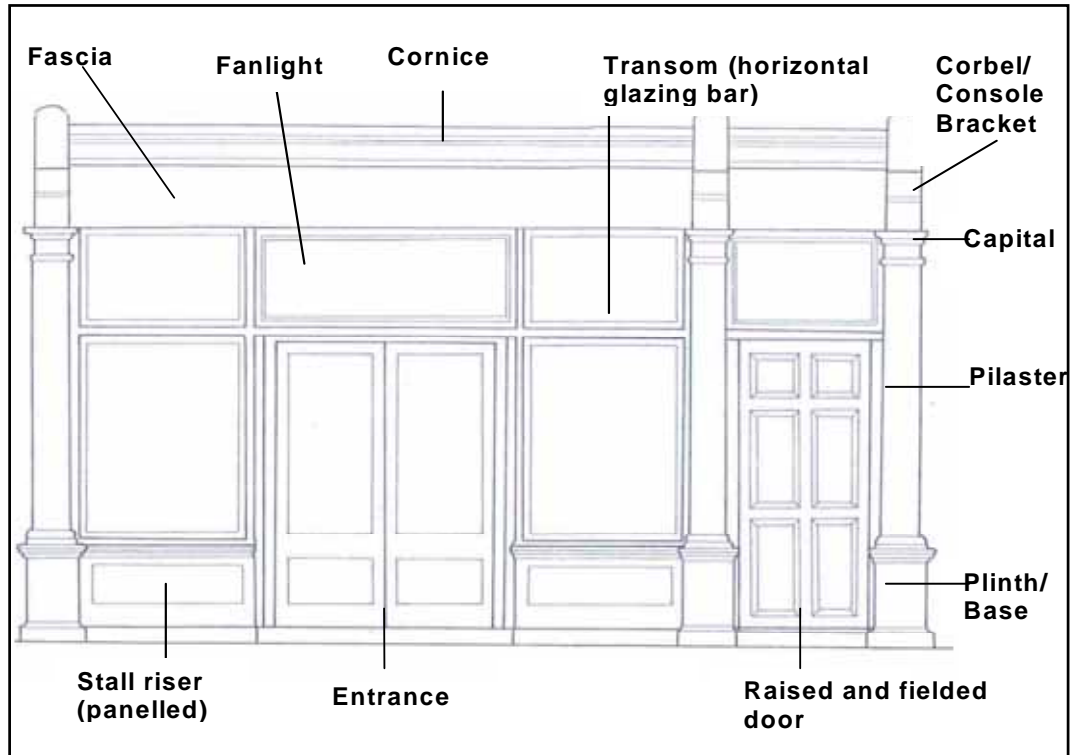

## **Fascia**

A fascia board is used the area used to display the name of the shop.

## **Fanlight**

The fanlight is often incorporated into the entrance design and can be used to display the property number.

## **Cornice**

The cornice provides a horizontal divide between the shop front and the upper floors.

## **Glazing (Transoms and Mullions)**

Transoms and Mullions are the horizontal and vertical divisions used to divide large expanses of glass. Any vertical divisions should reflect the vertical division on the upper floor.

## **Corbel/Console Bracket**

These provide support to the cornice and are found at the top of the pilasters located at either end of the shop front.

## **Pilaster**

Pilasters provide vertical framing to the shop front and provide visual support to the fascia and upper floors. They are a traditional building

feature designed with a base and capital and can also establish a visual division between neighbouring properties.

**Stall riser**

The stall riser forms a solid base to the shop front providing it with balanced proportions.

**Entrance**

The design and positioning of the door should reflect the character of the whole building. Any doorways providing independent access to upper floors should be positioned carefully within the design.

**N.B Opportunities for the different treatment of the elements above and the choice of materials available offer scope for a great variety in shop front design whether traditional or modern in style.**

## **2 Principles of Shop Front Design**

- 2.1 This section sets out some basic principles for shop fronts throughout the district. The guide sets out parameters within which to work and is not intended to restrict ideas or imagination but to encourage innovative yet sensitive solutions.
- 2.2 Whether designing a new shop or planning to alter or replace an existing one, it is important to consider the visual impact it will have upon the building and the wider streetscape. A shop front and building must be considered as a whole entity to ensure they are seen together rather than separate elements of the same building
- 2.3 Each street has a character and visual hierarchy that is established by the relationship between the buildings found there. If a shop front is to be successfully integrated into its surroundings, it will be required to respond to a number of established design criteria. Generally, new and refurbished shop fronts should follow the principles set out below:
- Respect the character of the existing building and its neighbours;
  - Reinforce the local character of the area and contribute to or create a sense of place;
  - Work towards enhancing the overall quality of the street scene;
  - Clear identity, not a mixture of styles;
  - Conserve existing historic features where possible, this may be essential if the building is listed;
  - Ensure neighbouring shopfronts are visually separate as to relate to each individual building;
  - Maintain existing proportions to ensure each floor/element is clearly defined;
  - Use symmetry and rhythm to relate shop fronts to upper floors, unless a strong horizontal emphasis exists to allow a different pattern;
  - Clearly define the entrance to the shop and make it accessible;
  - Integrate signs, lighting, and security measures into the overall design concept;
  - Adapt company 'house styles' to suit the individual character of the area and building, avoid using arbitrary repetition and stretched logos;
  - Use high quality materials and craftsmen;
  - Where a quality traditional shop front remains, preference should be given to refurbishment rather than replacement.

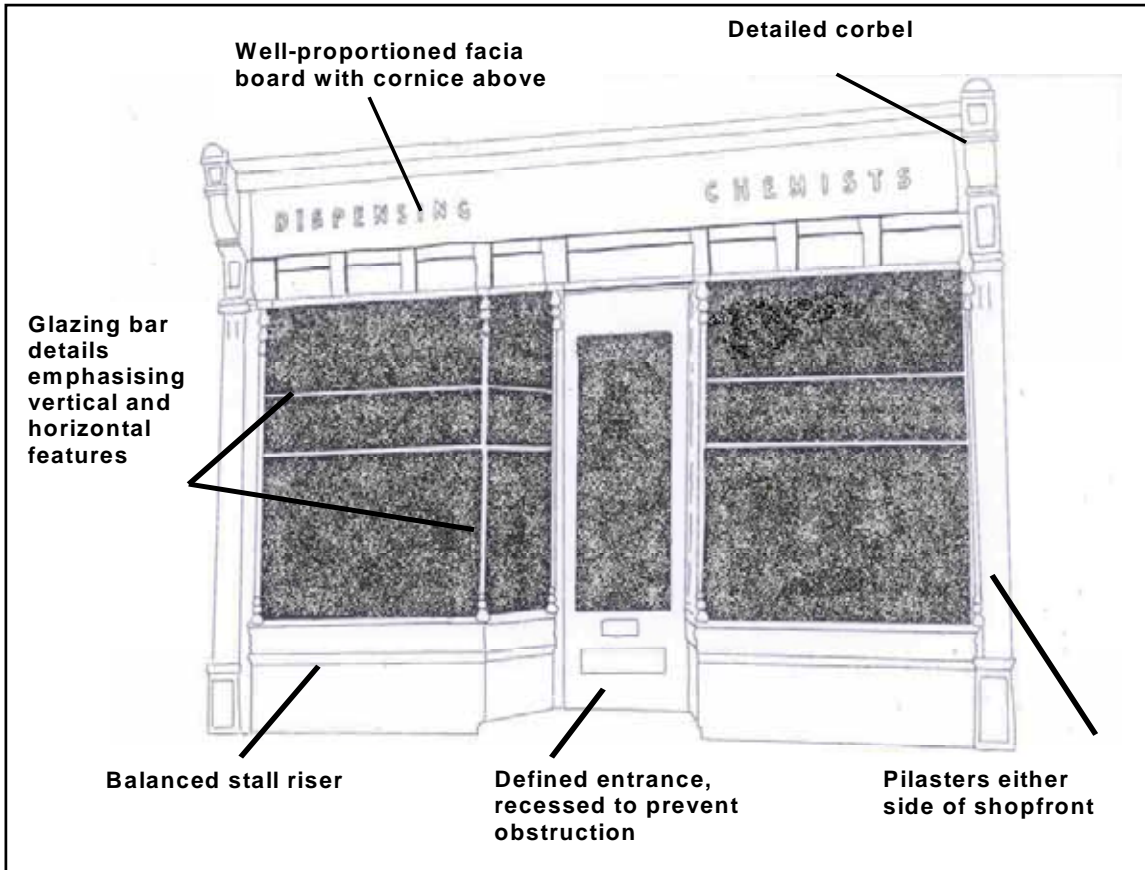

*Example of high quality shop front*

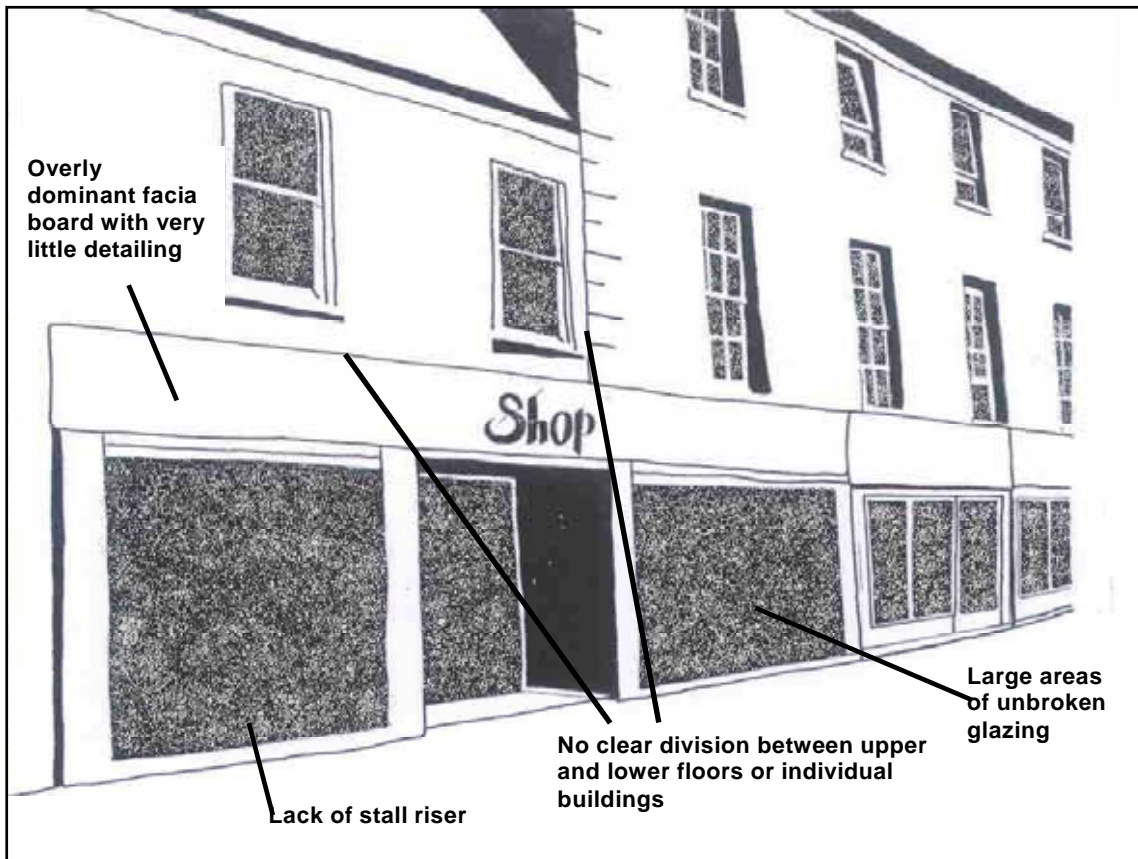

*Example of poor quality shop front*

### 3 Design criteria for quality shop fronts

#### 3.1 General principles

- 3.1.1 There are many instances where an original shop front will remain, hidden underneath later additions. For example, older fascias often lie beneath modern box fascias and pilasters and corbels were often boxed in as fashions changed. Where there is evidence of original details surviving, it may be desirable to retain and restore/refurbish any such features.
- 3.1.2 *The removal of a traditional shop front that is part of a Listed Building or within a Conservation Area will not be permitted if it is appropriate to the building or is of architectural or historic interest in its own right.*
- 3.1.3 *Permission for the replacement of traditional shop fronts in Listed Buildings or in Conservation Areas will only be granted if the existing shop front is inappropriate to the building or area and its replacement will be of high quality and improve the character of the building or area.*
- 3.1.4 Shop fronts and the buildings they occupy must be considered and designed as a whole unit within the street; they should not be designed in isolation. This is especially important when the building may be one of a group and the unity of design is an integral part of historic or architectural merit.

#### 3.2 Scale, height and proportion

- 3.2.1 The scale and height of a shop front must be in proportion with the rest of the building. This will allow the design of the shop front to fit within the original structural framework of the building.

- 3.2.2 Where a shop front is to cover more than one building, vertical subdivisions should be used to retain the individual appearance of each. This can be done by retaining dividing piers or pilasters, and respecting differences in adjacent fascias and stall risers. Individual fascias should be retained; conformity and linkage can still be achieved satisfactorily by continuity of lettering style, design

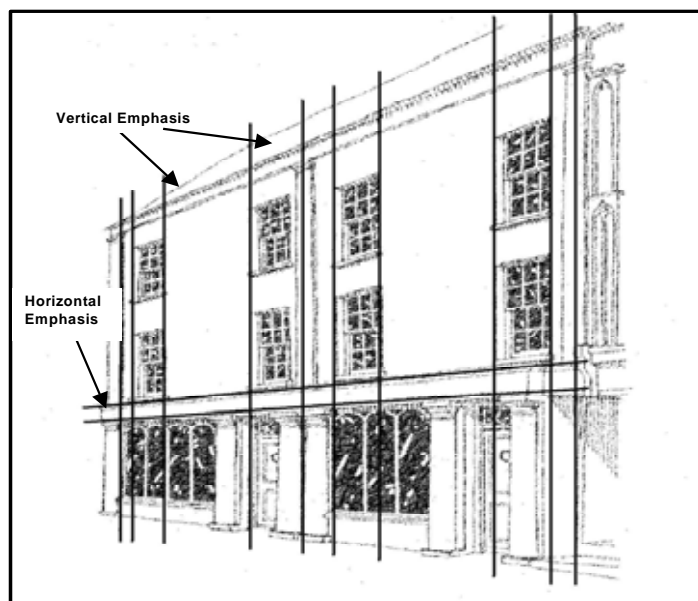



and colour.

### 3.3 Access for all

3.3.1 Access to shops has to be given special consideration, as required by the Disability Discrimination Act 1995. Every opportunity must be taken to ensure that access to and circulation within shops is possible for all members of the public.

3.3.2 All designs should conform to current standards of the Building Regulations where applicable. Further details are available for our Building Control Section.

3.3.3 Any solutions to conform to these requirements may need a creative and flexible approach, necessitating detailed discussions between the applicant and the Planning Service.

3.3.4 It should be remembered that the DDA is about access to Goods, Facilities and Services, not access to buildings; therefore there may be other ways of tackling this issue without compromising the architectural integrity of a particular building (for example, Listed Buildings).

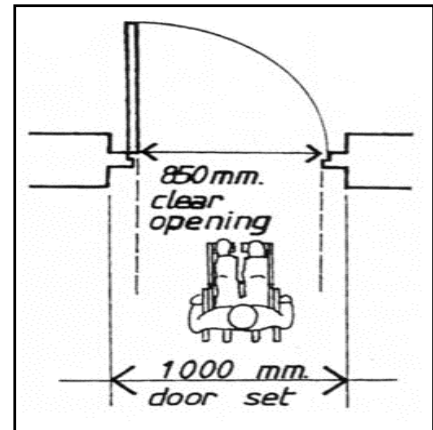

Current access requirements

### 3.4 Doors and Entrances

3.4.1 Changes in level at the main entrance and within shops should be avoided. If this cannot be done, a suitable ramp should be provided where possible.

3.4.2 Recessed doorways are a common feature in traditional shop fronts. They allow for an increased window area and a larger display. They can also be used to provide a level access by bridging any change in level between the shop floor and the street level.

3.4.3 The door must be easily distinguishable in the façade;



Well designed entrance way:

- Recessed
- Level Access
- Outward opening
- Easily distinguishable

recessing or using a detail colour can achieve this.

3.4.4 Doors should be easy to open, or automatic. Revolving doors should be avoided but if essential should be supplemented by hinged or sliding doors that are available at all times.

3.4.5 Glazed doors or large areas of glass should have visually contrasting areas in the form of a logo, sign or decorative feature at two levels in order to indicate their closed position.

### 3.5 Fascia and detailing

3.5.1 Oversized fascias being used to conceal a suspended ceiling inside the shop will not be appropriate. Other methods must be considered to hide a false ceiling. For example, setting the suspended ceiling back from the window or forming a splayed bulkhead.



*Overly dominant fascia board that detracts from an otherwise relatively balanced shop front*

3.5.2 A fascia should not extend beyond the shop front surround and should not stretch uninterrupted across a number of distinct buildings or architectural units.

3.5.3 The top of a fascia should be sited well below the sill of the first floor windows and should not obscure any existing architectural features or decoration (see illustration overleaf) that has a positive impact on the street scene.

3.5.4 Any detailing used to frame the fascia; for example a cornice, blind box, and/or corbels should be incorporated into the overall design of the shop front.

3.5.5 The cornice is an important part of shop front design, providing a horizontal line between the shop front and the upper floors as well as providing weather protection to the shop. If the projection is sufficient the cornice may be used to incorporate a trough light if appropriate.

*Fascia board located too close to the first floor window – no clear distinction between floors*



**Bold cornice detailing providing clear definition between the shop front and upper floor**



**Overly large pilasters and corbels successfully giving a traditional shop front design a contemporary twist**

- 3.5.6 Pilasters and corbels provide vertical framing for a shop front and establish physical separation from neighbouring buildings. They should be sufficient in size and number and appropriately located to provide visual support to the fascia and upper floors.
- 3.5.7 These are traditional features and may not be appropriate for a modern shop front design. However the principle of providing a clear division between shop fronts and visual support for the upper façade still applies. An appropriate way of achieving this in a modern design would be to

incorporate or retain flanking masonry piers and where necessary, include uprights within the shop front.

### 3.6 Stall riser

- 3.6.1 It should be noted that there would seldom be any situation where a stall riser is not required to complete the design of a frontage. It is often an integral design feature, providing support for the glazing and should therefore be a strong feature both in dimensions and structure.
- 3.6.2 The choice of depth will depend on the overall design of the shop front and can be influenced by the depth of the fascia.
- 3.6.3 Existing stall risers with decorative features of quality should be retained.
- 3.6.4 Materials used should always respect and enhance the materials of the whole building and shop front.
- 3.6.5 Contemporary designs should also incorporate some form of stall riser. These can be reinforced to provide additional security, can allow the display of goods at a more visible height and can help to create a horizontal link between adjoining buildings.



*Left:  
Lack of stall  
risers at ground  
floor level  
resulting in an  
unbalanced  
shop front*



*Right:  
Same shop front  
but with stall  
risers, dividing  
pilasters and  
cornices*

### 3.7 Windows and Glazing

- 3.7.1 The size and style of shop windows, including glazing bars, mullions and transoms must be in scale and proportion with the shop front and building as a whole.
- 3.7.2 Extensive areas of uninterrupted glazing will not normally be acceptable as this can create the effect of a void at ground level.
- 3.7.3 Where glazing in shop fronts is to be divided, the number and location of the divisions should ideally reflect any existing vertical divisions on the

upper floors. This will assist in providing visual support for the upper levels whilst providing a solid structural element at ground level.

- 3.7.4 This principle is acceptable for modern shop front designs, although subdivision is more commonly found on traditional shop fronts.

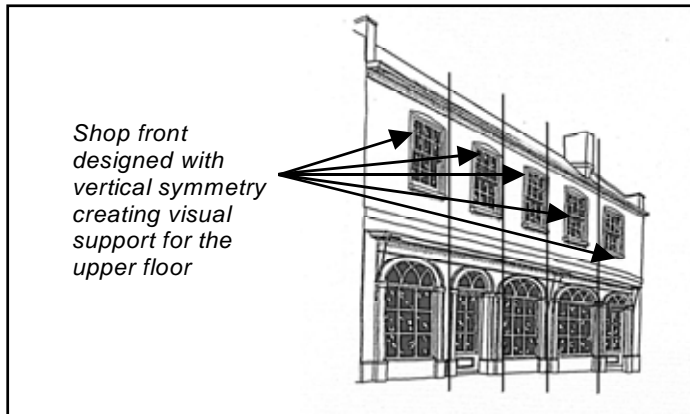

### 3.8 Materials

- 3.8.1 A high quality of materials and finish will be expected in any proposed shop front design.
- 3.8.2 The number of different materials and colours should be kept to a minimum to avoid a clash with the adjoining buildings and the overall character of the street.



- 3.8.3 On Listed Buildings and quality buildings within Conservation Areas the use of non-traditional materials will not normally be permitted (i.e. fibreglass or plastics) as their appearance often conflicts with the character of the building and area.
- 3.8.4 Timber is one of the most adaptable materials used in shop front construction. Ideally when dealing with traditional shop fronts, new or reinstatement/repair timber should be the primary material.

3.8.5 Other materials may be considered appropriate in specific locations or designs within the district. For example, metal frames, marble and brick may be appropriate if the building design and age lean towards the use of this type of material.



**3.9 Colour**

3.9.1 Any proposed colour scheme should be in keeping with the existing colour scheme on the building and adjoining buildings. It should enhance the design of the shop front and highlight any important decorative features present.

3.9.2 Whilst there is no approved colour palette for the District we would recommend taking a lead from existing buildings. The use of garish/vivid colours, not in keeping with the character of the area will not be appropriate and will not be supported.

3.9.3 Large areas of bright colour, particularly on shiny materials such as plastic should also be avoided.

*Garish colour which is visually dominant in the streetscape*



## 4 Other Key Elements of shop front design

### 4.1 Signs and advertising – general principles

4.1.1 The primary function of a shop front sign is to attract the attention of consumers and advertise essential information, for example the shop name, type of business, street number and if required the business address.

4.1.2 As a general rule, signs will not normally be permitted above fascia level. The size, location, colour, design, style of lettering and how it is illuminated all contribute to the appearance of a shop and character of a building. If designed well it can greatly enhance the appearance of the building and can also influence positively the trading success of a shop.

4.1.3 The adoption of a corporate design approach may not be considered appropriate for every building or street. Where standardised treatment would dominate or have a negative impact on a building or street, it is expected that the design will be modified. Corporate styles are acceptable only where they are subordinate to architectural considerations.



*Corporate image that has been successfully adapted to provide a high quality shop front*

4.1.4 Window stickers, poster displays and illuminated box signs in shop windows are often unsympathetic to the character of a building or area and would generally be discouraged. Window signs in upper floors will only be permitted for businesses operating solely on the upper floors.

4.1.5 The regulations covering advertising and signs are often complex and can be confusing, it is recommended if dealing with signage that you check with the local Planning Authority in the first instance to ascertain what consents may be required.

### 4.2 Fascia signs

4.2.1 Generally, one fascia sign per shop would be acceptable, as this is more effective than a number of individual signs all competing for attention.

4.2.2 As the fascia crowns the whole design of the shop front, it should be in proportion to others nearby as well as the building on which it is located.

- 4.2.3 Fascia signs should ideally be located at a minimum of 3 brick courses below the first floor windowsills and should not damage or cover any existing architectural feature.
- 4.2.4 Traditionally fascia signs were constructed of wood with hand painted lettering, this should be the case when designing or restoring a traditional shop front. The use of plastic will rarely be acceptable, especially on Listed Buildings or significant buildings within Conservation Areas.
- 4.2.5 Modern factory produced box signs will rarely be supported unless sited on modern buildings, provided they can be appropriately integrated.



### 4.3 Fascia sign lettering

- 4.3.1 The choice of lettering style used for the fascia sign is critical to achieving an attractive and enticing shop front. The nature of the business and the character of the building will often dictate this.



- 4.3.2 The content of signs should be kept to a minimum; any lettering and/or graphics should be in proportion to the dimensions of the fascia board. Oversized letters (in garish colours or materials) will not be supported and should be avoided, as should the repetition of a name on a single fascia.



- 4.3.3 The most appropriate location for lettering is on the fascia however there are some instances where lettering can successfully be incorporated in to the main window. This should always be done carefully paying great attention to the style colour and size of any design in order to minimise the impact on the character of the building and shop front.

#### 4.4 Hanging Signs

- 4.4.1 Hanging signs can add interest to the frontage of the shop as well as help identify a shop from a distance, however they are not appropriate in for all shop fronts or in all locations within the district.
- 4.4.2 Hanging signs and their supporting brackets must be carefully thought out to ensure the size, materials and detailing are appropriate in terms of scale and design.

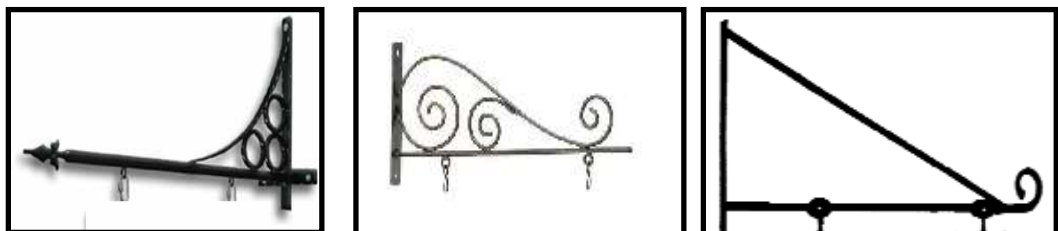

- 4.4.3 No more than one hanging sign on each elevation within a shop front will be permitted and they should be located at fascia level at one end of the fascia. In some instances it may be appropriate to site a hanging sign above the fascia level, however this will normally only be supported if it is to avoid damage to or covering up important architectural features.

- 4.4.4 As a general rule the bottom edge of the sign must be at least 2.6m above pavement level and the outer edge should not be within 1m of the kerb.

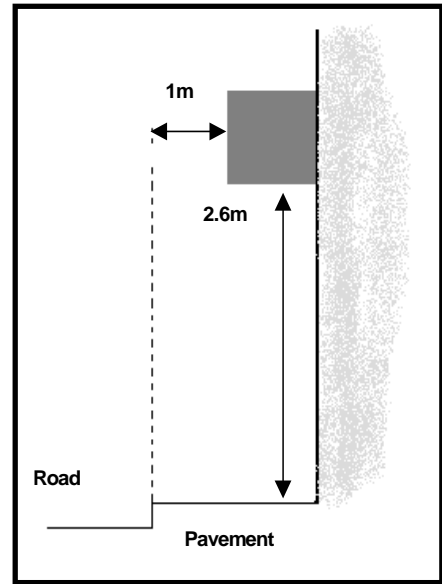

- 4.4.5 Where brackets already exist for hanging signs, these should be reused if they are of an appropriate design and suitable position. The design of new brackets should be appropriate to the shop front and kept relatively simple.

## 4.5 Box Signs

- 4.5.1 Box signs, whether illuminated or not often detract from the overall appearance of shop fronts and can be over dominant in the street scene. They can also damage or cover up significant architectural detailing on buildings.



- 4.5.2 Box signs will not be permitted in Conservation Areas or on Listed Buildings.
- 4.5.3 If a box sign is to be used on a modern building, it should attempt to have a minimum impact on the design of the overall shop front, ways of achieving this can include, being fully recessed behind the fascia, any lettering should be flush with the background panel or project only slightly and a matt finish can help improve aesthetic and visual appearance.

## 4.6 Nameplates

4.6.1 Often where the upper floor of a shop is in use by a separate business, there is a need for business nameplate located at the street entrance.

4.6.2 The size of such plates should be of modest proportion and should not be illuminated. If these are to be located on a Listed Building additional consents may be required. It is advisable to check with the Local Planning Authority in this instance.

## 4.7 Lighting

4.7.1 As a general rule, most illuminated signs will require Advertisement Consent. In Conservation Areas and on Listed Buildings all illuminated signs require Advertisement Consent.

4.7.2 It is possible to successfully incorporate lighting into a shop front design. Deciding on the most appropriate method, design and type of lighting will be key to ensuring it is not detrimental to the character or appearance of the building or area.



*Appropriate method of incorporating lighting into shop front design*

4.7.3 Internally illuminated fascia box signs and projecting signs are not in character with most retail areas in the district and will not be an acceptable form of illumination.

*Unacceptable form of illumination*



4.7.4 Where external lighting is proposed, it should be discreet and minimal. The use of intermittent light sources, moving features, exposed cathode tubing or reflective materials are not considered acceptable lighting solutions.

4.7.5 External lighting may be appropriate by the use of trough lights with a hood finish to match the background colour of the fascia. The use of large spotlights, swan-necks or heavy canopy lights should be avoided.



- 4.7.6 It may be more appropriate in some instances to consider the individual illumination of letters through halo background lighting. If this method is proposed the sign fascia should not be internally illuminated. For this method to be supported high quality design and materials will be necessary.



- 4.7.7 In many locations within the district illuminated signs are not considered appropriate due to the location and business opening hours. The Council will take into consideration the need for lighting when dealing with specific applications.
- 4.7.8 On hanging signs if illumination is proposed it should be very discreet and ideally attached to the bracket.
- 4.7.9 Lit window displays can have a positive impact on the vitality and sense of security within a shopping street. Carefully illuminated window displays using discreet light fittings rather than bare fluorescent tubes can create an attractive streetscape even out with trading hours. It should be noted that internally illuminated signs within 1m of a shop window would require Advertisement Consent.

#### **4.8 Blinds and Canopies**

- 4.8.1 Generally planning permission will be required to install a shop blind or canopy. If the canopy is to include advertising it may be that only Advertisement Consent is required. It is always best to check with the Local Planning Authority in the first instance.
- 4.8.2 The main purpose of a blind or canopy should be to provide protection from the weather, not to act as a permanent substitute for a fascia or projecting sign.
- 4.8.3 Where used, they should not detract from the style of the shop front or from the character of the building or street scene. Traditionally blinds were retractable and made of canvas with a blind box incorporated in to the cornice.
- 4.8.4 Where existing traditional blinds remain, we would encourage their retention and repair.
- 4.8.5 Blinds will generally not be permitted above ground floor level or over doors and should usually cover the whole width of the shop front. Care should be taken to ensure any blind does not obscure architectural features such as pilasters.



*Appropriate style of retractable shop front canopy*



*Inappropriate Dutch style canopy with over-dominant advertising*

4.8.6 All canopies and blinds will be required to provide a vertical clearance of 2.3m from the footpath and a horizontal clearance of 1m from the kerb edge. They should not interfere with visibility of traffic signs or signals.

4.8.7 In Conservation Areas and on Listed Buildings, Dutch or balloon canopies or any form of plastic canopy will not be permitted. Canvas is the preferred material and colours should match or be in keeping with the fascia colours. Garish colour schemes should be avoided.

4.8.8 Any lettering should be minimal and should not dominate the canopy area. The lettering style should co-ordinate with the design of the shop front as a whole, especially the fascia sign.

#### **4.9 Security**

4.9.1 Proposals for security should be considered during the design stage and not as an after thought. Any security measures should be an integral part of the shop front design and should endeavour to provide the least visually intrusive measures.

4.9.2 It is important to recognise the need to achieve a balance between the need to address the security needs of any shop and the owners whilst responding to the wider environmental and public interests. Many security measures can have a detrimental impact on the character or a streetscape and can create unwelcoming, 'dead' frontages.

4.9.3 The following security measures should be avoided and will not generally be supported:

- External shuttering of any kind;
- Solid shutters that prevent visibility into the shop outside operating hours;
- Horizontal slats that are at odds with a shop front with a predominantly vertical emphasis;
- Security housing that break up the otherwise well-proportioned elements of the frontage.

4.9.4 External solid roller shutters would not be considered acceptable. The following are recommended as acceptable alternatives:

- Security (laminated) Glass that has the capacity to remain intact even when broken. Toughened Glass or architectural Perspex are similar alternatives;
- Internal security grilles that can be fitted discreetly behind the shop window. These should be perforated and designed to be in keeping with the design of the shop front.

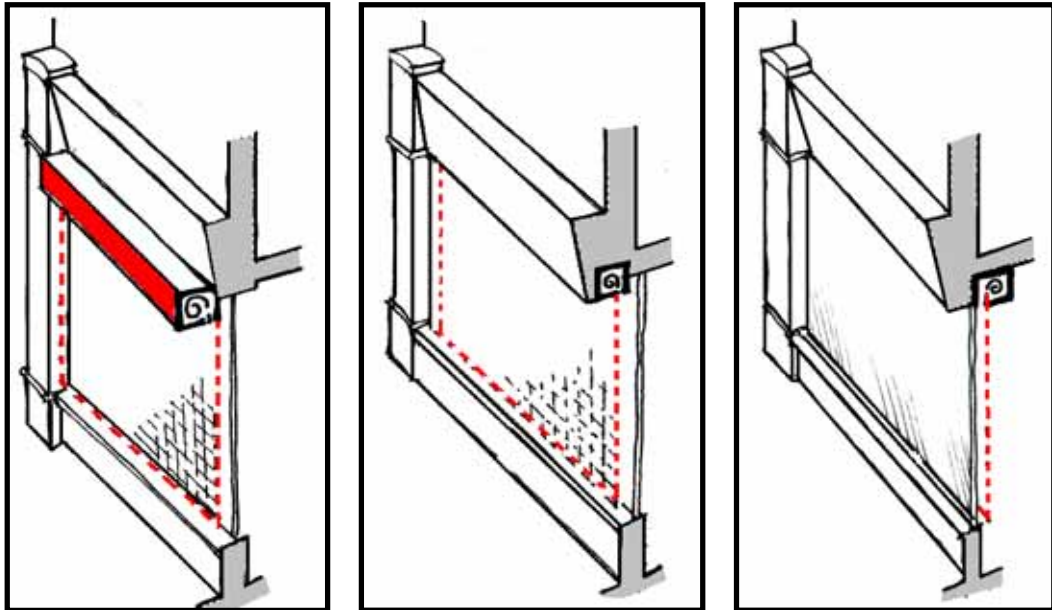

*External roller shutter that detracts from the shop front and will not be appropriate*

*External shuttering with housing concealed in fascia – least favourable alternative*

*Internal security shutters having minimal impact on shop front*

4.9.5 External collapsible gates or wrought ironwork can often be another alternative. If proposed the following criteria should be observed:

- The window display should still be easily visible;
- Any associated mechanisms and housing should be concealed behind the external structure (i.e. behind the fascia or recessed and flush with the shop front).
- The fascia, stall riser and pilasters should not be covered by the grille;
- Runners or shutter guides should be either removable or integrated into the pilasters or glazing bars and painted to match;
- The grille itself should be painted in a colour appropriate to the rest of the shop front;
- No part of the grille or its housing should obscure or damage any important architectural features present on the shop front.

4.9.6 Unobtrusive strengthening of the shop front to protect against ram raiding is possible using elements of a traditional shop front. It is relatively easy to provide a reinforced stall riser by introducing concrete or steel behind the

front façade. Steel can also be introduced behind transoms and mullions to provide additional strengthening.



*External decorative grilles providing security and transparency*



*Roller shutters creating a dead frontage with no visual transparency into shop*

- 4.9.7 A common security feature is the use of fire and burglar alarms and while often essential these can often be unattractive and obtrusive if sited incorrectly. Alarms are best incorporated on centrelines between upper windows or within recessed doorways. Alarms should never be sited on architectural features such as corbels or pilasters.

#### **4.10 Permissions required for Installation of security measures**

##### **4.10.1 Planning Permission**

This will be required for all forms of external shuttering and for any other security measure that affects the buildings appearance. Fire and burglar alarms will not generally require planning consent.

##### **4.10.2 Listed Building Consent**

This will be required for any alterations to a Listed Building, including external shuttering, internal measures which will be highly visible, affect the character of the building or involve the disturbance of historic fabric. It will also be required for the installation of fire alarms, burglar alarms and any ventilation units.

It is always advisable to contact the Conservation Team for advice on works to a Listed Building.

N.B Listed Building Consent is required **in addition to** planning permission.

##### **4.10.3 Building Regulation Approval**

Alterations that affect the structure of a building may require Building Regulation Approval. This is required in addition to any other forms of consent.

It is advisable to contact the Building Control Team for any advice prior to undertaking works.

## **5 Useful Contacts**

If you require any further advice or information regarding shop front design please contact:

**Development Control**

East Cambridgeshire District Council

The Grange

Nutholt Lane

Ely

Cambs

CB7 4EE

**T:** 01353 665555

**E:** [planning@eastcambs.gov.uk](mailto:planning@eastcambs.gov.uk)



## Summary of the adopted Core Strategy Policies relevant to this SPD

### Policy EN 2

#### **Design**

All development will be designed to a high quality, reinforcing local distinctiveness. Design which fails to have regard to local context and does not preserve or enhance the character, appearance and quality of an area will not be acceptable.

New development proposals, extensions and alterations to existing buildings and structures will be expected to:

- a. Have regard to the East Cambridgeshire Design Guide
- b. Incorporate the sustainable construction principles contained in Policy EN3
- c. Make efficient use of land while respecting the density, character, landscape and biodiversity of the surrounding area.
- d. Be developed in a comprehensive way, avoiding piecemeal development
- e. Retain existing important landscaping and natural and historic features and include landscape enhancement schemes that are compatible with the Council's Landscape Guidelines for recreation and biodiversity
- f. Ensure that the scale, massing and materials of buildings relate sympathetically to the surrounding area
- g. Provide structure by making use of existing views, vistas and landmarks and creating new ones
- h. Create safe environments addressing crime prevention and community safety
- i. Make a clear distinction between public and private spaces, and enhance the public realm
- j. Ensure that places and buildings are accessible to all, including the elderly and those with impaired mobility
- k. Provide enclosure to street and spaces through the grouping, positioning and height of buildings and landscape features, and road layouts
- l. Incorporate the highway and access principles contained in Policy S6
- m. Ensure that car parking is discrete and accessible and provided in accordance with Policy S7
- n. Provide adequate waste and recycling storage/collection areas
- o. Where appropriate, contain a variety and mix of uses, buildings and landscaping
- p. Ensure there is no significantly detrimental effect on the residential amenity of nearby occupiers, and that occupiers of new dwellings are provided with acceptable residential amenity
- q. Ensure that there is no detrimental effect on the appreciation of Ely as an historic cathedral city in the quality of the approaches and the quality of views of the cathedral distant and close to.

The Council may require the submission of development briefs for certain proposals, and will notify developers of this requirement at an early stage in the conception of proposals.

### Policy EN 5

## Historic conservation

Development proposals, within, or affecting a Conservation Area should:

- Be of a particularly high standard of design and materials that will preserve or enhance the character or appearance of the area
- Retain attractive traditional features such as original doors, windows and boundary walls
- Only involve the demolition of buildings where:
  - They are of little or no importance to the architectural, historic or visual character or appearance of the area; or
  - They are structurally unsound (for reasons other than deliberate damage or neglect) and beyond reasonable repair, and measures to sustain an existing use or find an alternative use have been explored and failed; and in all cases
  - Detailed proposals for reconstruction or redevelopment have received planning permission.

Proposals to extend alter or change the use of a Listed Building, or which affect the setting of a Listed Building will only be permitted where they would:

- Preserve the building or its setting or any features of special architectural or historic interest which it possesses; and
- Support the long-term preservation of the building.

Proposals to demolish all or part of a Listed Building will only be permitted in very exceptional cases where:

- The building is structurally unsound (for reasons other than deliberate damage or neglect) and beyond all reasonable repair; and
- All possible measures to sustain an existing use or find an alternative use have been explored and failed, and preservation in charitable or community ownership is not possible or sustainable; or
- Where redevelopment would bring wider public benefits; and
- Preservation in a charitable or community ownership is not possible or suitable; and
- Detailed proposals for reconstruction or redevelopment have received planning permission.

The Council will take action to enforce repair of Listed Buildings where appropriate.